



Satisfy Professional's Needs

Cordless Concrete Vibrator

BVR850 2,400mm (8.0ft) / **BVR450** 1,200mm (4.0ft) / **BVR350** 800mm (2.6ft)
BVR440 1,200mm (4.0ft) / **BVR340** 800mm (2.6ft)



**Ergonomic Design and
Smooth Mixing**

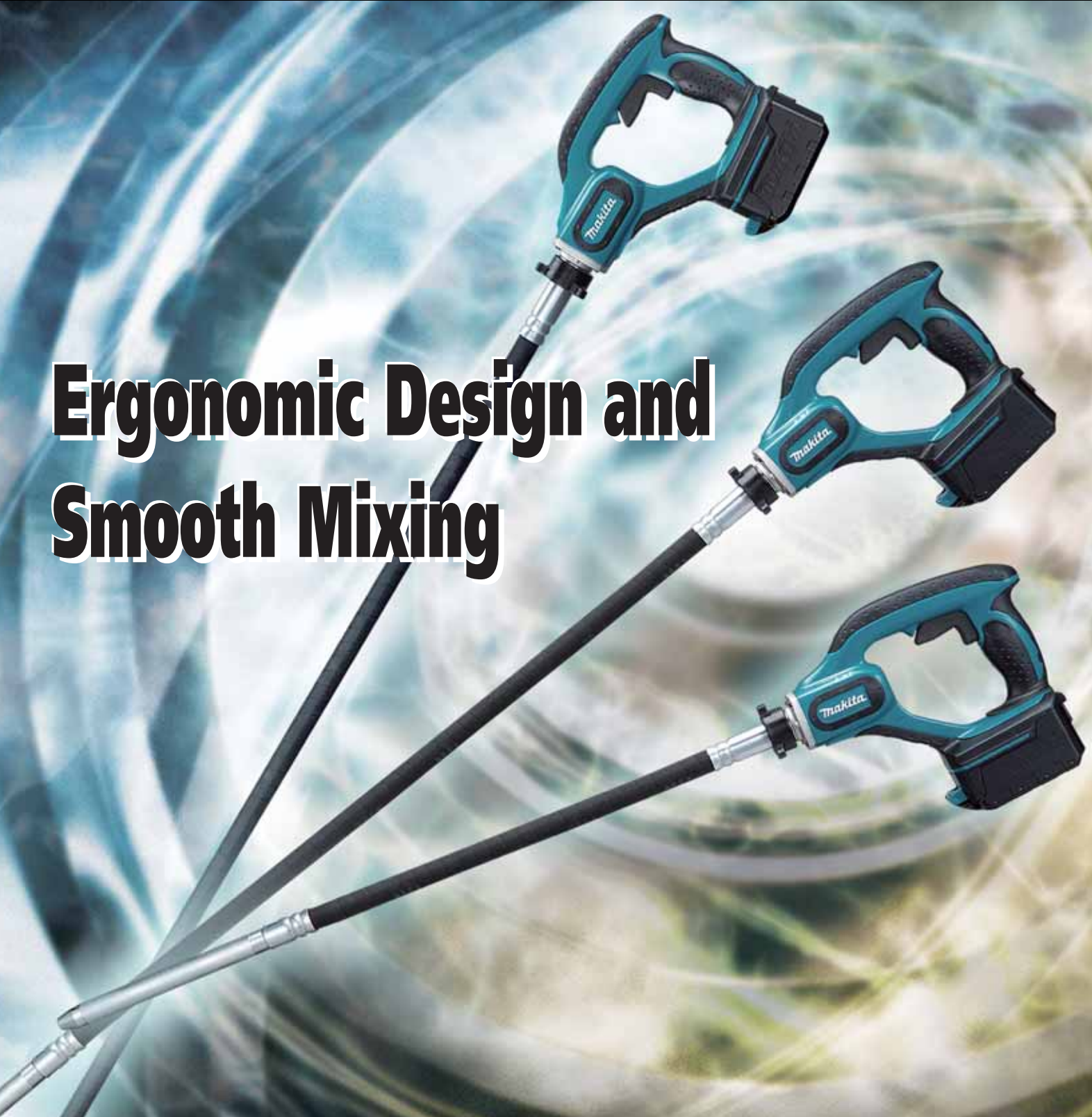

LITHIUM-ION



Increased maneuverability with new trigger operable from two directions.



The switch can be pulled also with the top portion of the grip held by hand, enabling to use the machine as a plunger.

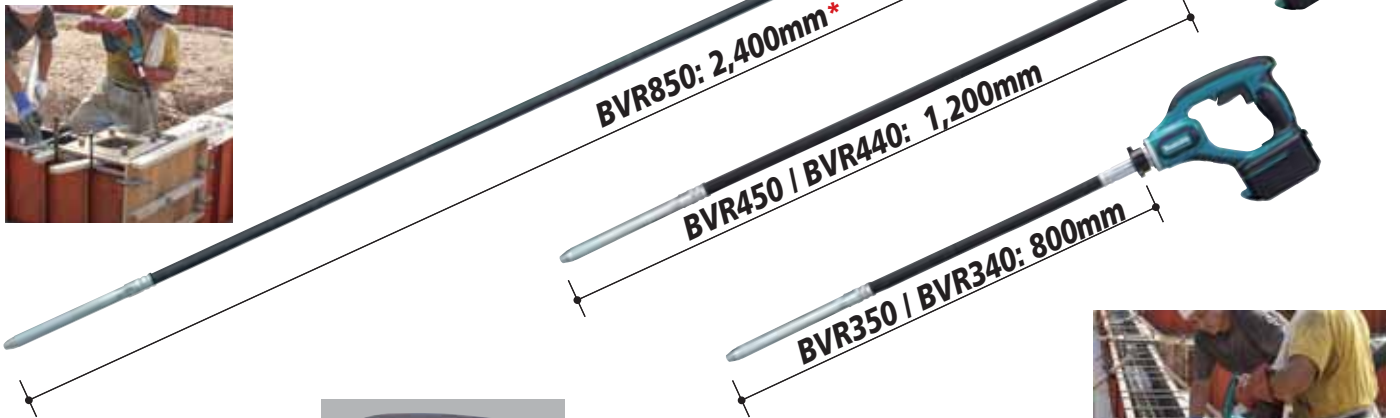

Best-Fitting Grip

Ergonomically designed for maximum efficiency and minimum fatigue in the operation.



* BVR850 features the longest in this class. This 2,400mm flexible shaft is pretty effective with leveling and removal of air-bubble in deep founds.



Cordless Concrete Vibrator	BVR850 2,400mm (8.0ft) / BVR450 1,200mm (4.0ft) / BVR350 800mm (2.6ft) BVR440 1,200mm (4.0ft) / BVR340 800mm (2.6ft)				
	BVR850	BVR450	BVR350	BVR440	BVR340
Carrying Case (for Battery and Charger)					
Diameter of vibrator	25mm (1")	25mm (1")	25mm (1")	25mm (1")	25mm (1")
Length of flexible part	2,400mm (8.0ft)	1,200mm (4.0ft)	800mm (2.6ft)	1,200mm (4.0ft)	800mm (2.6ft)
Vibrations per minute	12,500vpm	13,000vpm	13,000vpm	12,500vpm	12,500vpm
Dimensions (L x W x H)	2,683 x 93 x 250mm (105-112" x 3-5/8" x 9-7/8")	1,483 x 93 x 250mm (58-112" x 3-5/8" x 9-7/8")	1,083 x 93 x 250mm (42-3/4" x 3-5/8" x 9-7/8")	1,483 x 93 x 250mm (58-112" x 3-5/8" x 9-7/8")	1,083 x 93 x 250mm (42-3/4" x 3-5/8" x 9-7/8")
Net weight	5.3kg (11.7lbs)	3.7kg (8.2lbs)	3.2kg (7.1lbs)	3.6kg (7.9lbs)	3.1kg (6.8lbs)
Voltage	18V	18V	18V	14.4V	14.4V
Standard Equipment	Fast Charger, Battery Cartridge		Items of standard equipment and specifications may differ from country to country.		

EXTREME STAMINA

Life time work volume

430%

in comparison with Makita Ni-cd 2.0Ah batteries

Total Power Delivery Amount of each battery's service lifetime



The numbers in the chart are relative values when the amount of Ni-cd 2.0Ah is indexed at 100.

LIGHTWEIGHT & COMPACT

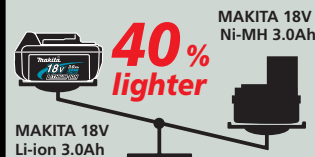

- ANYTIME CHARGE NO MEMORY EFFECT
- LONGTIME STORAGE
- LOW SELF DISCHARGE
- SHOCK ABSORBING HEAVY DUTY PACK
- FIRM HOLDING MULTI CONTACT

430% Only Achieved with...

MAKSTAR Charger's Optimum Charging System

- :: Communicates with individual battery.
- :: Recognizes ID of battery and its history.
- :: Analyzes its condition; Battery may have been abused by heat or over-discharging, or weakened by cycle age.
- :: Charges optimum and gentle way with Active 3 Controls;
 - Active Current Control
 - Active Thermal Control
 - Active Voltage Control
- :: Knows how to look after each MAKSTAR battery to MAXIMIZE CYCLE LIFE + WORK VOLUME.

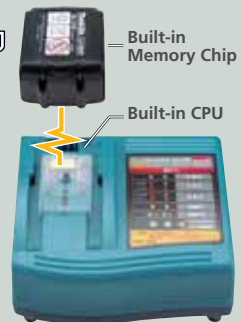
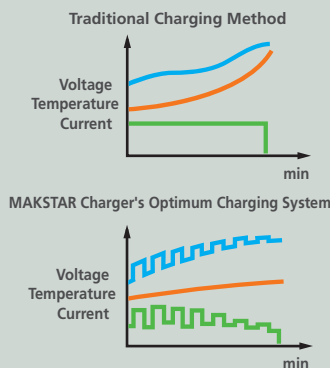

:: Cools down inside battery.

Makita Corporation

3-11-8 Sumiyoshi-cho, Anjo, Aichi, 446-8502 Japan

PRINTED IN JAPAN Z15205-2 2006-09